

LM3508 Evaluation Board

National Semiconductor
Application Note 1593
Travis Eichhorn
June 2007



Introduction

The LM3508 is a synchronous step-up DC/DC converter designed for white LED applications. The evaluation board is set up to drive 4 standard V_F white LEDs from a 2.7V to 5.5V input supply. A fifth LED can be placed across the R1 pad for testing

up to 5 low VF LEDs. The LED current is set using the RSET resistor via the equation $I_{LED} = 0.2V/RSET$. The evaluation board comes with RSET = 10Ω for approximately 20 mA LED current. LED dimming is achieved by applying a PWM waveform of up to 100kHz to the DIM pin.

Schematic

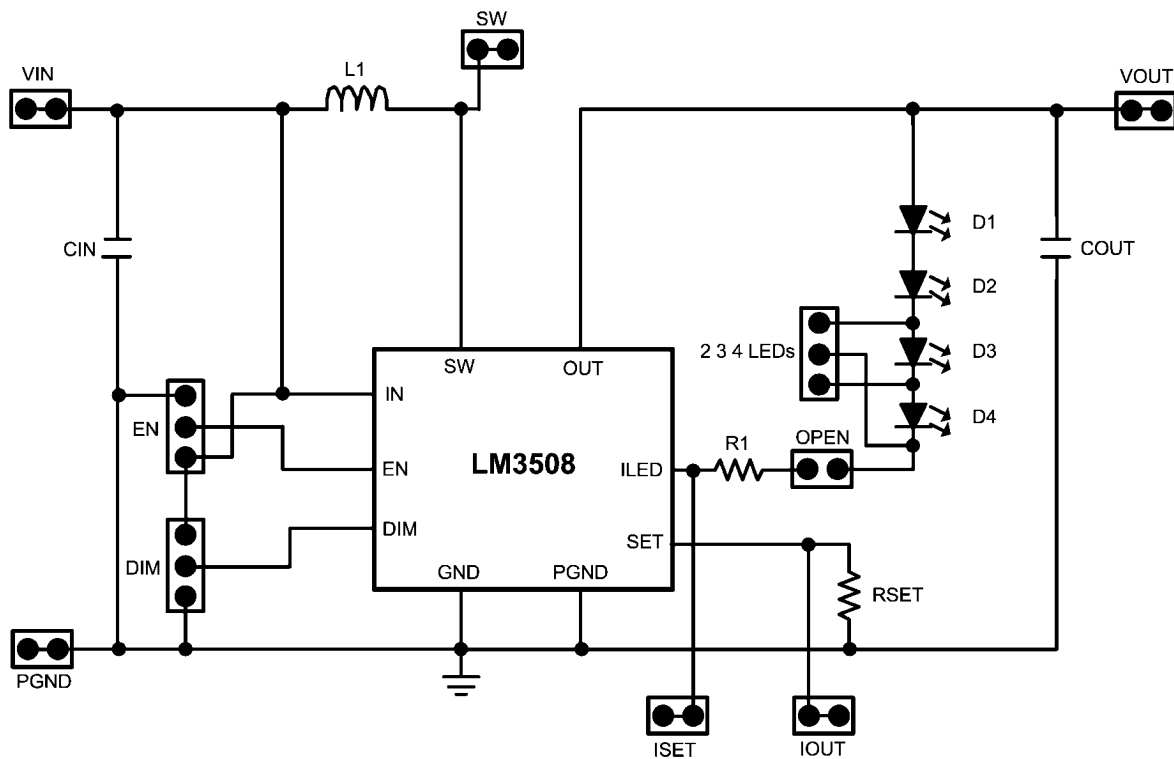

30011001

Bill of Materials

Designator	Component	Part Number	Manufacturer
U1	LM3508TL, μSMD 9-bump	LM3508	National Semiconductor
L	22 μH, ISAT = 330mA	VLF3010AT-220MR33	TDK
CIN	1 μF, 10V Ceramic	C1608JB1A105M	TDK
COUT	1 μF, 25V Ceramic C3216X7R1E105K	C1608JB1E105M	TDK
D1–D3	White LED	LW M67C	Osram
R1	0Ω Resistor	CRCW0603	Vishay
R1	10Ω Resistor	CRCW060310R0F	Vishay

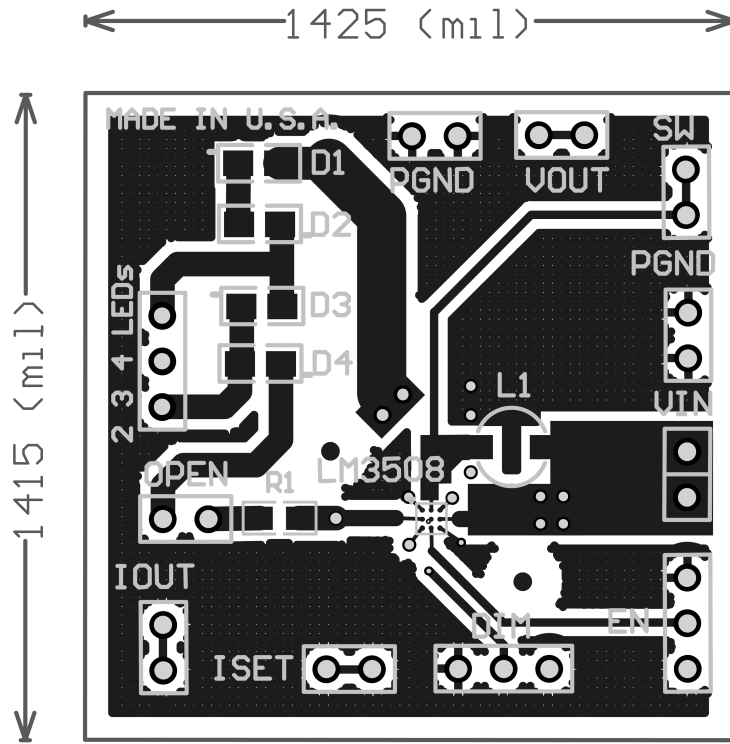

FIGURE 1. LM3508 Evaluation Board Layout Topside

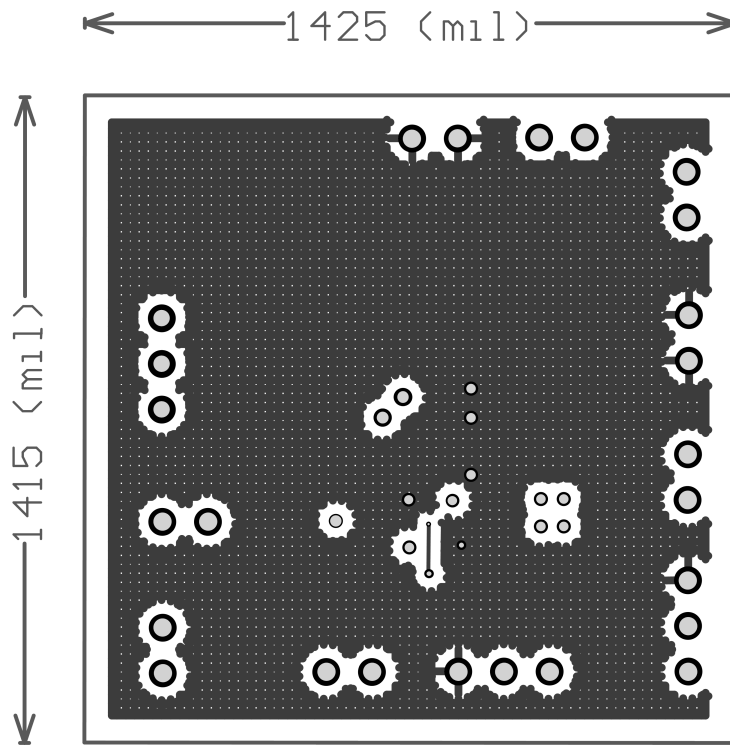

FIGURE 2. LM3508 Evaluation Board Layout Mid Layer 1

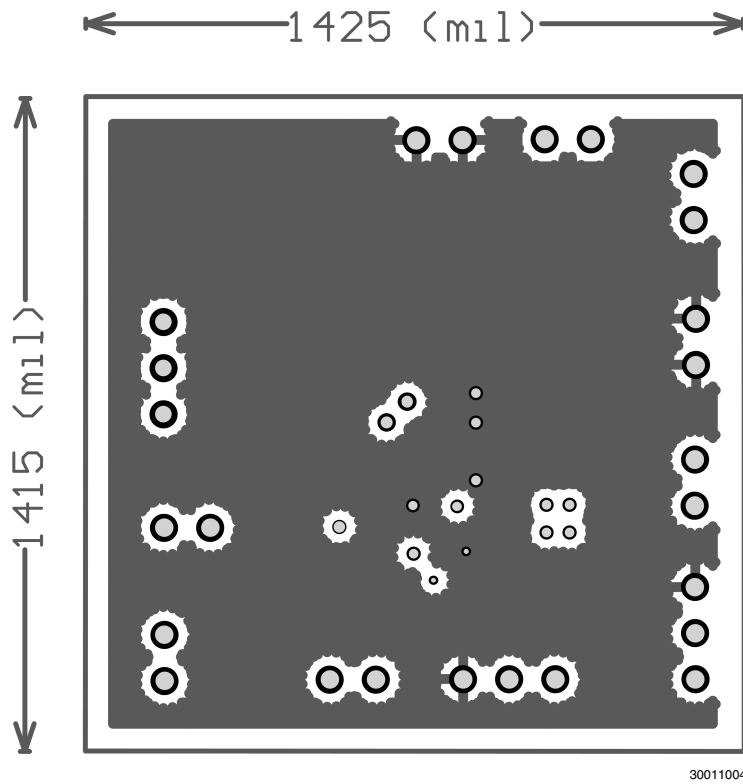

FIGURE 3. LM3508 Evaluation Board Layout Mid Layer 2

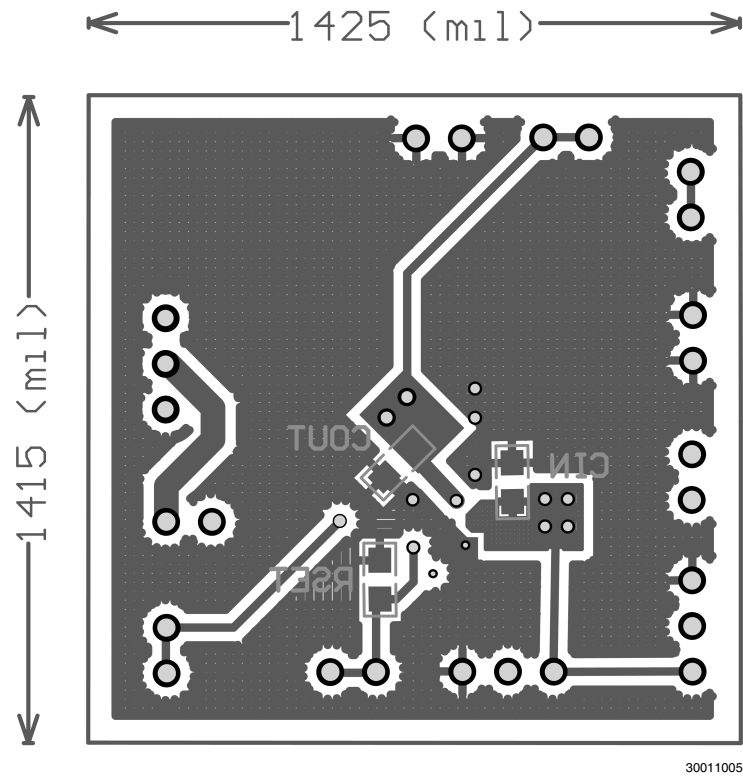

FIGURE 4. LM3508 Evaluation Board Layout Bottom Side

Board Operation

To operate the LM3508 evaluation board, connect a 2.7V to 5.5V supply between the VIN header and PGND.

Jumper Connections

- EN is a 3-position jumper (see bottom right jumper in figure 2). The middle pin connects to EN of the device. The top pin of the EN header connects to PGND (device disabled) and the bottom pin connects to VIN (device enabled).
- DIM is a 3-position header (see figure 2). The middle pin connects to DIM of the LM3508. The left pin of the DIM header connects to PGND (current source off). The right pin connects to VIN (current source on with max LED current of 20mA). Drive DIM with a PWM waveform ($V_H > 1.1V$, $V_L < 0.5V$) at up to 100kHz to adjust the LED brightness.
- 2 3 4 LEDs is a 3-position header (see figure 2). Leave open to configure the board for 4 series LEDs. Place a jumper

across the top and middle pin to short D3 and D4 (2 LED solution). Place a jumper across the bottom and middle pin to short only D4 (3 LED solution).

- The OPEN header opens the current path from the cathode of D4 and the input to the current source. Normally this is shorted. This is for demonstrating OVP and/or disconnecting the LEDs.

R1 is a short (0Ω) this can be replaced with a sense resistor for measuring the LED current or replaced with a 5th LED for evaluation of low VF LEDs. EN has an internal $383k\Omega$ pull-down resistor placing the part in shutdown by default. DIM also has an internal $383k\Omega$ pull-down resistor turning off the current source by default. For more information regarding the operation of the LM3508 please refer to the LM3508 datasheet.

Notes

AN-1593

Notes

THE CONTENTS OF THIS DOCUMENT ARE PROVIDED IN CONNECTION WITH NATIONAL SEMICONDUCTOR CORPORATION ("NATIONAL") PRODUCTS. NATIONAL MAKES NO REPRESENTATIONS OR WARRANTIES WITH RESPECT TO THE ACCURACY OR COMPLETENESS OF THE CONTENTS OF THIS PUBLICATION AND RESERVES THE RIGHT TO MAKE CHANGES TO SPECIFICATIONS AND PRODUCT DESCRIPTIONS AT ANY TIME WITHOUT NOTICE. NO LICENSE, WHETHER EXPRESS, IMPLIED, ARISING BY ESTOPPEL OR OTHERWISE, TO ANY INTELLECTUAL PROPERTY RIGHTS IS GRANTED BY THIS DOCUMENT.

TESTING AND OTHER QUALITY CONTROLS ARE USED TO THE EXTENT NATIONAL DEEMS NECESSARY TO SUPPORT NATIONAL'S PRODUCT WARRANTY. EXCEPT WHERE MANDATED BY GOVERNMENT REQUIREMENTS, TESTING OF ALL PARAMETERS OF EACH PRODUCT IS NOT NECESSARILY PERFORMED. NATIONAL ASSUMES NO LIABILITY FOR APPLICATIONS ASSISTANCE OR BUYER PRODUCT DESIGN. BUYERS ARE RESPONSIBLE FOR THEIR PRODUCTS AND APPLICATIONS USING NATIONAL COMPONENTS. PRIOR TO USING OR DISTRIBUTING ANY PRODUCTS THAT INCLUDE NATIONAL COMPONENTS, BUYERS SHOULD PROVIDE ADEQUATE DESIGN, TESTING AND OPERATING SAFEGUARDS.

EXCEPT AS PROVIDED IN NATIONAL'S TERMS AND CONDITIONS OF SALE FOR SUCH PRODUCTS, NATIONAL ASSUMES NO LIABILITY WHATSOEVER, AND NATIONAL DISCLAIMS ANY EXPRESS OR IMPLIED WARRANTY RELATING TO THE SALE AND/OR USE OF NATIONAL PRODUCTS INCLUDING LIABILITY OR WARRANTIES RELATING TO FITNESS FOR A PARTICULAR PURPOSE, MERCHANTABILITY, OR INFRINGEMENT OF ANY PATENT, COPYRIGHT OR OTHER INTELLECTUAL PROPERTY RIGHT.

LIFE SUPPORT POLICY

NATIONAL'S PRODUCTS ARE NOT AUTHORIZED FOR USE AS CRITICAL COMPONENTS IN LIFE SUPPORT DEVICES OR SYSTEMS WITHOUT THE EXPRESS PRIOR WRITTEN APPROVAL OF THE CHIEF EXECUTIVE OFFICER AND GENERAL COUNSEL OF NATIONAL SEMICONDUCTOR CORPORATION. As used herein:

Life support devices or systems are devices which (a) are intended for surgical implant into the body, or (b) support or sustain life and whose failure to perform when properly used in accordance with instructions for use provided in the labeling can be reasonably expected to result in a significant injury to the user. A critical component is any component in a life support device or system whose failure to perform can be reasonably expected to cause the failure of the life support device or system or to affect its safety or effectiveness.

National Semiconductor and the National Semiconductor logo are registered trademarks of National Semiconductor Corporation. All other brand or product names may be trademarks or registered trademarks of their respective holders.

Copyright© 2007 National Semiconductor Corporation

For the most current product information visit us at www.national.com



National Semiconductor Americas Customer Support Center
 Email: new.feedback@nsc.com
 Tel: 1-800-272-9959

National Semiconductor Europe Customer Support Center
 Fax: +49 (0) 180-530-85-86
 Email: europe.support@nsc.com
 Deutsch Tel: +49 (0) 69 9508 6208
 English Tel: +49 (0) 870 24 0 2171
 Français Tel: +33 (0) 1 41 91 8790

National Semiconductor Asia Pacific Customer Support Center
 Email: ap.support@nsc.com

National Semiconductor Japan Customer Support Center
 Fax: 81-3-5639-7507
 Email: jpn.feedback@nsc.com
 Tel: 81-3-5639-7560